

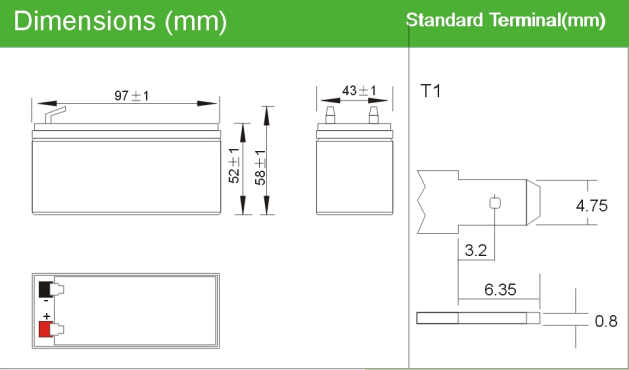

DJW12-1.5 (12V1.5AH)



Physical Specification		
Nominal Voltage		12V
Nominal Capacity (20HR)		1.5AH
Dimension	Length	97±1mm (3.82 inches)
	Width	43±1mm (1.69 inches)
	Container Height	52±1mm (2.04 inches)
	Total Height (with Terminal)	58±1mm (2.28 inches)
Weight		Approx 0.65kg (1.43lbs)
Standard Terminal		T1(standard)

Discharging Current & Discharge Duration Time

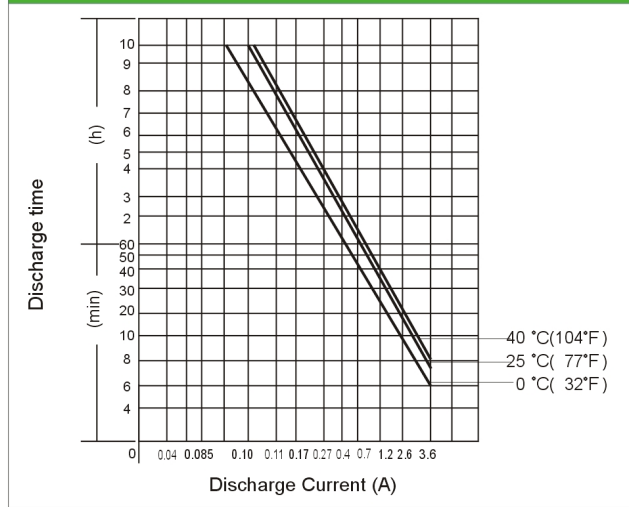

Electrical Specification					
Rated Capacity	20 hour rate (75mA)	1.50AH	Constant-Voltage Charge	Cycle	Initial Charging Current less than 0.45A. Voltage 14.4V~ 15.0V at 25°C (77°F) Temp. Coefficient -30mV/°C
	10 hour rate (138mA)	1.38AH			
	5 hour rate (260mA)	1.3AH			
	1 hour rate (930mA)	0.93AH			
Capacity affected by Temperature	15minute rate (2.94A)	0.735AH	Standby	No limit on Initial Charging Current Voltage 13.5V~13.8V at 25°C(77°F) Temp. Coefficient - 20mV/°C	
	40°C (104°F)	103%			
	25°C (77°F)	100%			
	0°C (32°F)	86%			

Discharge Characteristics (25°C, 77°F)

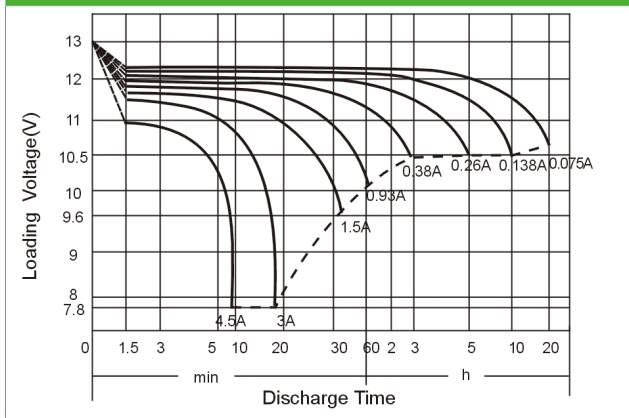

Constant Current (Amp) and Constant Power (Watt) Discharge Table (25°C, 77°F)

Time(minute) Final voltage/Cell	5	10	15	20	30	45	60	120	180	300	600	1200
Amp/Watt/Cell	1.3	1.3	1.3	1.3	1.6	1.6	1.67	1.7	1.75	1.75	1.75	1.8
A	6.37	3.90	2.94	2.24	1.63	1.17	0.93	0.51	0.37	0.26	0.138	0.075
W	10.79	7.42	5.63	4.39	3.21	2.33	1.86	1.01	0.73	0.52	0.26	0.14